

» AGS54 – Outdoor Temperature Sensor passive

Application

Outdoor temperature measurement, in cold stores and greenhouses, production plants and warehouses. Designed to be used with control and monitoring systems.

TECHNICAL DATA	
Ambient temperature	-31°F...+194°F (enclosure)
Terminal clamp	Terminal block connection, max. 15 AWG
Enclosure	Material PA6, colour pure white (similar to RAL9010), with quick release fastener screws
Cable entry	M16, 1/2" NPT Adapter
Protection	NEMA 4
Notice	Other sensors on request



Connection passive

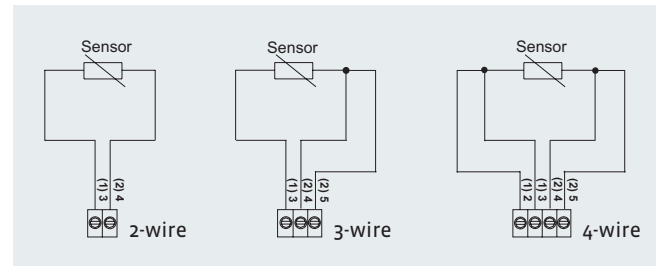

Dimensional Drawing ("inch)

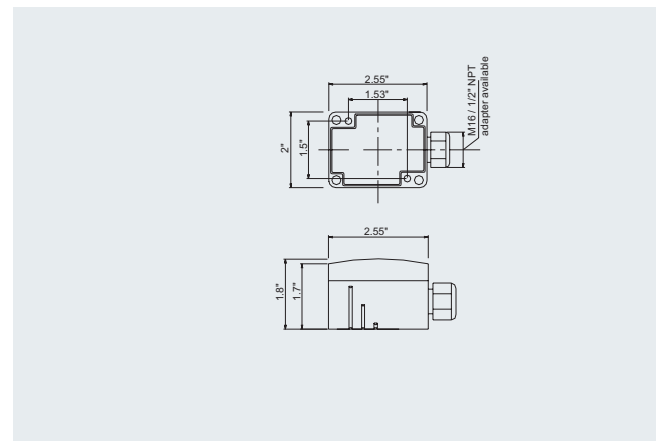

PASSIVE	
AGS54	PG1
Type	Art. No.
AGS54 without sensor	199902
AGS54 PT100	25263
AGS54 PT100 1/3DIN	25270
AGS54 PT1000	25287
AGS54 PT1000 1/3 DIN	25294
AGS54 Ni1000	25300
AGS54 Ni1000TK5000	25317
AGS54 FeT	25331
AGS54 NTC1,8k	132534
AGS54 NTC5k	25362
AGS54 10K2	25379
AGS54 10K3	25416
AGS54 NTC20k	25386
AGS54 KTY81-110	25430
AGS54 KTY81-121	25447
AGS54 KTY81-122	25454
AGS54 KTY81-210	25461
AGS54 LM235Z	25485

OPTIONS	
AGS54	PG1
Description	
Aluminium enclosure	

ACCESSORIES	
AGS54	PG1
Description	Art. No.
Rawplugs and screws (2 pcs. each)	102209
Sun-/rain protection RS150	103329

